

The 722 Pressure Regulator can be used for direct service (simple stage regulation) and for first and last stage regulations, either in small installations or in industries.

Its excellent design makes it the proper regulator for abrupt pressure changes since it does not produce excessive freezing.

Four models of this type are produced, depending on the regulated pressure:

- 722-1: up to 0,05 bar
- 722-2: from 0,05 to 0,9 bar
- 722-3: from 0,9 to 1 bar
- 722-A: from 1 to 1,25 bar

All of them support inlet pressures of up to 28 bar.

#### TECHNICAL DATA

Connections:	Inlet : 3/4" BSP / left screw 885 NGO (POL) Outlet : 3/4" BSP
Operation temperature:	-20°C to 60°C (-10°F to 140°F)
Aprox weight:	2,1 Kg (722) or 2,4 Kg (722A) 4,6 Lbs (722) or 5,3 Lbs (722A)
Accuracy Class	AC10
Close Pressure Class	SG20
According to Standard	EN-334

#### MATERIALS

INLET BODY/ SEAT ORIFICE:	Forged brass
DIAPHRAGM:	Acrole nitrile
SEAT MATERIAL:	Acrole nitrile (722) or Teflon (722A)

#### DIMENSIONS in mm.

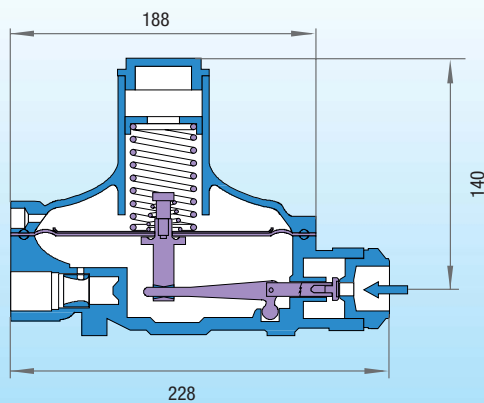

Pressure Regulator

**EQA 722**

## Pressure Regulator

# EQA 722

### USAGE

It can be used for natural gas (density 0,6), LPG (density 1,5) and other gases (see chart)

### STRUCTURE

It is highly solid, its diaphragm is made nitrile and its inner parts are anticorrosive. Both the diaphragm and its inner parts resistant to hydrocarbon action. The system is equipped with a safety relief valve that vents possible excesses in outlet pressures.

### INSTALLATION

#### Connections

Inlet : 3/4" BSP / 3/4" NPT (optional) / left srew 885 NGO (POL)

Outlet : 3/4" BSP / 3/4" NPT (optional)

It can be connected equally to vertical or horizontal pipes. The diaphragm plane can also be positioned horizontally or vertically no matter the position of the regulator.

It is recommended to leave the spring tap within easy reach in order to be able to make adjustments in outlet pressures.

### ORIFICES

Different orifice diameters are available for different inlet and outlet pressures: 5/32" (4 mm), 3/16" (4,8 mm), 1/4" (6,4 mm) and 3/8" (9,5 mm).

### SPRING RANGES

Outlet pressures of regulators type 722 are regulated through the adjustment of the different springs provided.



## CAPACITY CHART FOR NATURAL GAS

Capacity chart in Nm <sup>3</sup> /hour (Density 0,6 - Droop 10%)					
Outlet Pressure (mbar)	Inlet pressure (bar)	Orifice Diameter			
		5/32"	3/16"	1/4"	3/8"
Range 0.015 a 0.033	0.140	6	8	10	18
	0.350	9	12	20	36
	0.500	12	18	26	40
	1.00	15	22	37	40
	1.50	22	28	40	40
	2.00	26	40	40	40
	2.50	30	40	40	40
	3.50	34	40	40	40
	5.00	40	40	40	-
	7.00	40	40	40	-
Range 0.03 a 0.08	0.140	5	6	8	11
	0.350	8	10	12	25
	0.500	11	12	14	38
	1.00	15	17	30	58
	1.50	20	27	45	65
	2.00	24	35	56	65
	2.50	30	40	56	65
	3.50	37	52	56	65
	5.00	49	56	56	65
	7.00	54	56	56	65
Range 0.08 a 0.18	0.350	8	9	11	15
	0.500	10	12	15	32
	1.00	16	18	21	45
	1.50	22	25	32	80
	2.00	26	32	40	90
	2.50	35	38	54	90
	3.50	39	40	82	90
	5.00	54	68	90	90
	7.00	67	80	90	-
	10.00	67	80	90	-
Range 0.18 a 0.35	0.500	8	9	10	13
	1.00	15	16	18	32
	1.50	20	22	24	48
	2.00	22	28	30	70
	2.50	26	33	40	100
	3.50	33	45	64	120
	5.00	45	60	90	120
	7.00	62	78	120	-
	10.00	70	78	-	-
	15.00	91	-	-	-
21.00	91	-	-	-	
28.00	91	-	-	-	

In order to calculate capacities with other gases, multiply the value in the chart by K factor

GAS	DENSITY relative to air	K FACTOR
Butane	2	0.55
Propane (LPG)	1.5	0.63
Carbonic Anhydride	1.5	0.63
Oxygen	1.1	0.74
Air	1	0.77
Nitrogen	0.97	0.79

Capacity chart in Nm <sup>3</sup> /hour (Density 0,6 - Droop 10%)						
Outlet Pressure (mbar)	Inlet pressure (bar)	Orifice Diameter				
		5/32"	3/16"	1/4"	3/8"	
Range 0.35 a 0.7	1.00	11	12	14	18	
	1.50	13	14	20	32	
	2.00	18	19	28	39	
	2.50	20	23	34	48	
	3.50	32	34	39	70	
	5.00	50	52	52	100	
	7.00	64	66	100	130	
	10.00	70	75	-	-	
	15.00	85	-	-	-	
	21.00	128	-	-	-	
Range 0.7 a 1	2.50	11	20	30	40	
	3.50	17	25	55	50	
	5.00	25	45	55	70	
	7.50	30	70	80	90	
	10.00	40	96	-	-	
	15.00	48	100	-	-	
	21.00	50	-	-	-	
	28.00	54	-	-	-	
	<b>722-A Model</b>					
	1	2.5	11	20	30	40
3.5		17	25	35	50	
5		25	45	55	70	
7.5		30	70	80	90	
10		40	96	-	-	
15		48	100	-	-	
1.5	2.5	13	20	30	40	
	3.5	20	30	35	45	
	5	30	50	60	70	
	7.5	40	75	85	95	
	10	45	100	-	-	
	15	54	100	-	-	
2	3	20	25	30	30	
	5	35	55	70	70	
	7.5	50	80	90	95	
	10	55	110	-	-	
	15	66	110	-	-	
	21	70	-	-	-	
2.5	3	17	20	25	25	
	5	35	50	70	70	
	7.5	50	80	95	95	
	10	65	100	-	-	
	15	78	100	-	-	
	21	85	-	-	-	
28	90	-	-	-		

GAS	DENSITY relative to air	K FACTOR
Acetylene	0.9	0.82
Ammonia	0.59	1.02
Hydrogen	0.07	3
Biogas*	máx 1.2	0.7
	mín 0.8	0.75

\* The proper operation is guaranteed only for treated Biogas (Low content of sulfur).

## CONVERSION UNITS

To obtain	Pounds per Square Inch	Inches of Water Column	Milimeters of Water Column	Inches of Mercury	Milimeters of Mercury	Bar	Milibar	Kilograms per Square centimeter	Kilopascals
Multiply	<b>psi</b>	<b>in H2O</b>	<b>mm H2O</b>	<b>in Hg</b>	<b>mm Hg</b>	<b>bar</b>	<b>mbar</b>	<b>kg/cm<sup>2</sup></b>	<b>Kpa</b>
<b>psi</b>	1	27,68	703,1	2,036	51,7	0,06895	68,95	0,0703	6,895
<b>in H2O</b>	0,0361	1	25,4	0,07355	1,87	0,002491	2,491	0,00254	0,22491
<b>mm H2O</b>	0,0014	0,0394	1	0,00289	0,07355	0,000098	0,0981	0,0001	0,00981
<b>in Hg</b>	0,4911	13,6	345,4	1	25,4	0,03386	33,86	0,03453	3,386
<b>mm Hg</b>	0,01934	0,535	13,6	0,03937	1	0,001333	1,333	0,00136	0,1333
<b>bar</b>	14,5	401,5	10198,1	29,53	750,06	1	1000	1,02	100
<b>mbar</b>	0,0145	0,4015	10,1981	0,02953	0,7501	0,0001	1	0,00102	0,1
<b>Kg/cm<sup>2</sup></b>	14,22	393,7	10000	28,96	735,58	0,9807	980,7	1	98,07
<b>Kpa</b>	0,145	4,015	101,98	0,2953	7,501	0,01	10	0,0102	1

## FLOW CONVERSIONS

To obtain	Standard Cubic Feet per Hour	Standard Cubic Meter per Hour	Standard Cubic Feet per Day	Standard Cubic Meter per Day
Multiply	<b>Scf/h</b>	<b>Scm/h</b>	<b>Scf/d</b>	<b>Scm/d</b>
<b>Standard Cubic Feet per Hour</b>	1	0,028	24	0,672
<b>Std. Cubic Meter per Hour (15°C, 1.01325 bara)</b>	35,71	1	857,04	24
<b>Standard Cubic Feet per Day</b>	0,0417	0,0012	1	0,028
<b>Standard Cubic Meter per Day</b>	1,4879	0,0417	35,71	1

### EQA S.A.I.C.

26 de abril 3836 - ITUZAINGO (1714) - Pcia. de Buenos Aires  
 Tel. (54 11) 4481-9950 / Fax.(54 11) 4481-9288  
 e-mail: eqa@eqa.com.ar - web site: www.eqa.com.ar

### DISTRIBUIDOR | DISTRIBUTOR