

ATTENTION

Before installation or any maintenance on the regulator, read carefully this manual and strictly follow instructions given.

This regulator must be installed, operated and maintained according to the standards of the equipment or the place where they are installed and according to this manual.

Manufacturer is not responsible for damages due to misuse or wrong operating procedures due generated by a lack of knowledge of this manual content.

Any gas leak outside the valve indicates that the gas supply must be shut off and technical assistance must be contacted.

Only a qualified technician should install or repair the regulator.

When a replacement or technical assistance is requested, mention the information shown on the identification plate of the regulator (model - serial number – pressures - orifice diameter - flow).

This equipment has been manufactured to operate safely and without risks within the design conditions and only if the following points are observed:

1. Installation, operation and maintenance are performed by skilled personnel fully experienced with this type of equipment and familiar with the contents of this manual, all activity are carried out in strict adherence with instructions given in this manual.

2. Operating conditions and, in particular, pressure and temperature, are within the design value of the equipment.

Different use or modifications carried out not in accordance with manufacturer written instructions are not allowed. The user will be responsible for damages or injuries due to improper use, guarantee will be immediately terminated in case of improper use.

This equipment contains pressure containing parts, therefore any operation or maintenance activity shall be performed only by skilled and qualified personnel aware of the precautions to be taken. Before opening any part of the equipment make sure that pressure has been completely relieved.

PREVENTION

Before starting installation and maintenance operations carry out the following check list.

1. Personnel in charge of the activity is skilled, trained to this type of equipment and fully aware of the content of this manual
2. All necessary prevention measures have been taken before commencing the job in accordance with these manual and local regulations.
3. Operator is equipped with necessary tools and consumables required to safely and correctly apply the procedures described.
4. All necessary spare parts are available and they are original spare parts of EQA S.A.I.C

INSTALLATION

Before installing the regulator, check it for any damage on shipping. Be sure there is no dirt inside its body.

It is advisable to install two pressure gauges, one upstream and one downstream of the regulator.

Vent inlet pipe several times until no particles appear. (This is the main cause of failures in start-ups).

The regulator can be installed in any position. Gas circulation must coincide with the arrow on valve's main body. The vent hole should not be obstructed or exposed to rain or dust. The regulator should also be protected from vehicular traffic. The pilot venting hole must be checked periodically to verify it has no obstructions.

It is recommended to have a dual regulation piping to avoid a gas interruption while doing maintenance or reparations.



The equipment is designed for dry, clean natural gas: do not use liquid or corrosive substances or gas with solid particles.
All installation and operating procedures must be performed slowly.
Avoid fast actions during opening and closing of the upstream and downstream valves.
Do not exceed pressure range as specified on the equipment nameplate.

START-UP

After completing installation, check that the upstream and downstream isolation valves, the downstream vent valve and any by-pass lines are closed.



Be sure to slowly introduce pressure into the system to prevent downstream overpressure due to potential rapid pressure increase. It is advisable to carry out start up with manometers appropriate the inlet pressure and outlet of the regulator to monitor this procedure.

- 1- Open upstream valve slowly.
- 2- Check that the outlet pressure is within the range shown on the identification plate.
- 3- Open downstream valve slowly.
- 4- Check carefully all tubing connections for possible leakage. Remember that vibrations and shocks during transport may loosen fittings.

ADJUSTMENT

Turn the regulation screw clockwise to increase the outlet pressure and turn it counter-clockwise to decrease it.

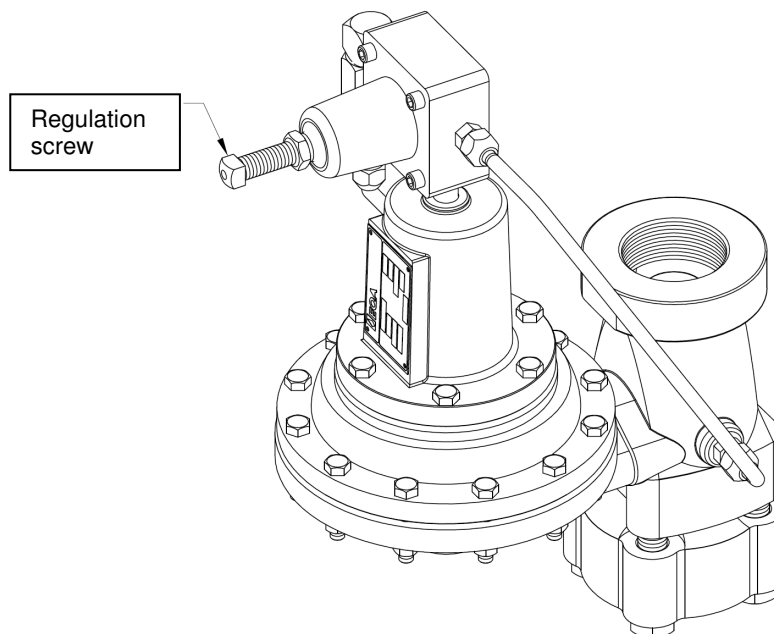

If you increase the outlet pressure, security elements such as relief valves, shutoff valves or pressure switches may act in case of overcoming their pressure settings.
The identification plate of the regulator should also be updated to avoid possible confusions.

PERIODIC FUNCTIONAL CHECKS



The continuing integrity of gas pressure regulators and lock safety valve is assured by periodic functional checks.

What is presented here is Manufacturer recommendation for a minimum level of check required to maintain continuity of integrity of gas pressure regulators and lock safety valve.

The following checks and preventative maintenance activities shall be performed and recorded according to user quality system.

The intervals given are intended to support user in the management of preventative maintenance.

Very aggressive or demanding services may require a reduction of the intervals proposed as well as critical services with high availability index.



It is user responsibility to establish a suitable interval to perform the periodic functional checks required by the type of service conditions, criticality of service and local regulations.

PERIOD	ACTIVITY
1 year	Perform a complete series of functional checks.
3 years	Change dynamic seals and check diaphragms
5 years	Change all seals and diaphragms

The following functional checks are described.

- Regulator operation
- Regulator tightness.



Periodic functional checks described herein require that the pressure reducing line in which the equipment to be checked are installed be taken out of service and available for performing the periodical checks only.

FUNCTIONAL CHECK REGULATOR:

Close the downstream isolation valve VERY SLOWLY so that the regulator close and there is no overpressure in the downstream piping.

In order to verify if the movement of the regulator shutter is smooth, modify regulator shutter position by modifying the opening degree of the vent valve, simulating changes in consumption.

If the movement of manometer is not smooth, but rough and bumping, it means that friction in the moving parts is too high and the regulator requires maintenance.

FUNCTIONAL CHECK REGULATOR TIGHTNESS:

- a) Close VERY SLOWLY the downstream isolation valve.
- b) Close SLOWLY the downstream vent valve.
- c) Check that the outlet pressure is stable.
- d) If the pressure increases, it means that the regulator does not close perfectly.

REPLACEMENTS

They must be ordered according to the part numbers shown on the drawings and the serial number shown on the identification plate of the regulator.

MAINTENANCE

Before beginning any maintenance operation, follow the instructions below:



- Check that there are no parts under pressure between the two isolation valves.
- Close VERY SLOWLY downstream isolation valve to close the regulator.
- Close VERY SLOWLY upstream isolation valve.
- Completely vent the upstream and downstream pipes, with the downstream vent valve.
- ENSURE THAT THE SYSTEM IS COMPLETELY DE-PRESSURISED.

INSPECTION AND PART REPLACEMENT

- 1-Close all valves after releasing any remaining pressure between the valves and the regulator.
- 2-Remove inlet pipe (631.00.08) and outlet pipe (631.00.13).
- 3-Remove the 6 screws (INS.87.25) to separate diaphragm cover (631.00.17) and pilot (631.00.11).
- 4-Measure spring (631.00.16) position and then unscrew spring pusher (631.00.14) to loosen spring (631.00.16).
- 5-Remove the 4 screws (INS.87.39 or INS.86.99) from inlet body (631.00.01) to separate bodies. Orifice (630.00.02) and gaskets (630.00.24) should be released.
- 6-Check the orifice seat (630.00.02). If it is scratched, replace along with gaskets (630.00.24).

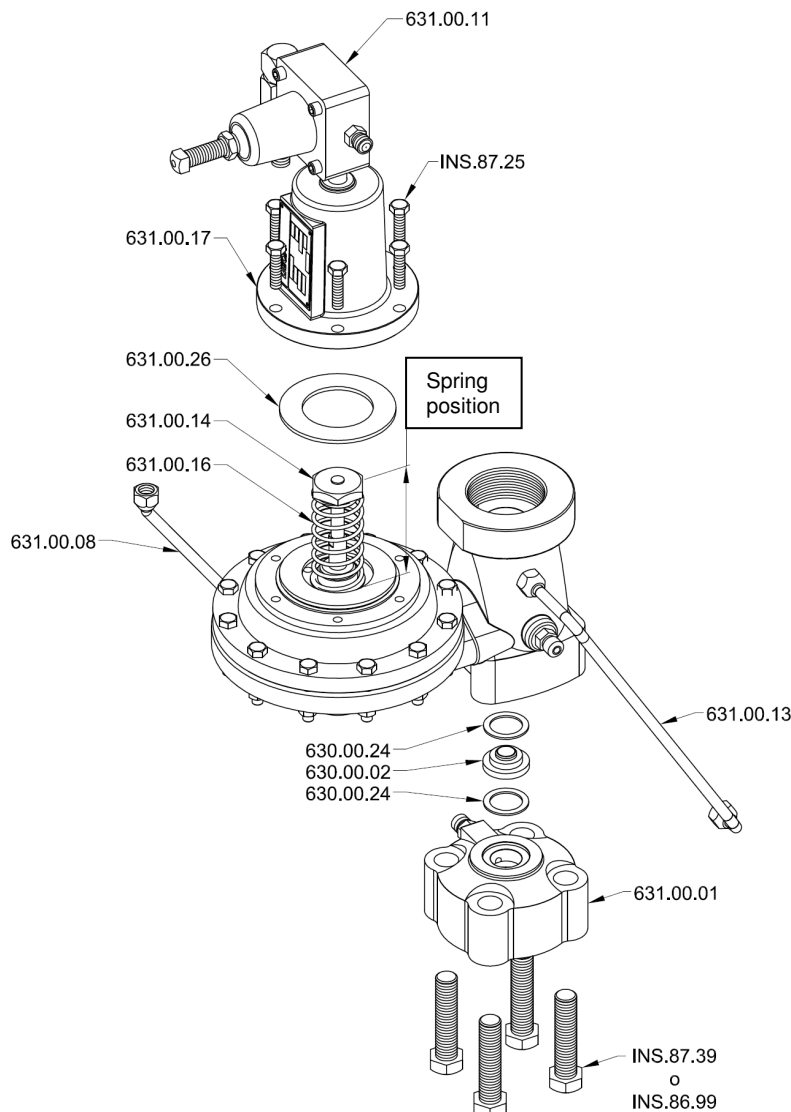

- 7- Check the shutter (630.00.03SUB) into the outlet body (630.00.07), if it is too scratched or has any encrusted particle it must be replaced. To change it, it is necessary to remove the 2 screws (INS.86.88) releasing the outlet body (630.00.07), the lever (630.00.06), the shutter stem (630.00.05) and shutter (630.00.03SUB).

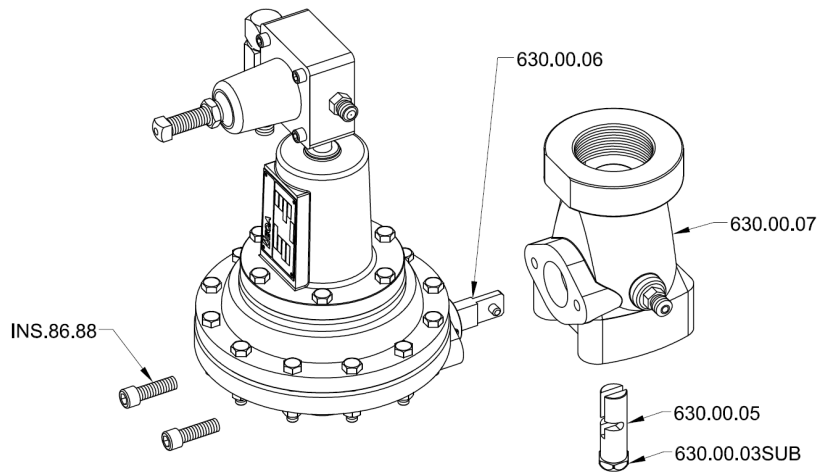

To remove the shutter (630.00.03SUB) from the shutter stem (630.00.05), unscrew the shutter (630.00.03SUB) holding the shutter stem (630.00.05). Keep the washers that are between the two pieces as they affect performance.

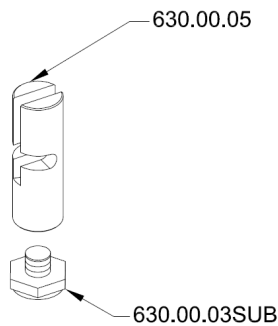

8-Once replaced elements reassemble the unit following the instructions in reverse order.
CAUTION: DO NOT lubricate or oil any part of the regulator.

9-To replace the diaphragm (630.00.21), remove the 6 screws (INS.87.25) releasing diaphragm cover (631.00.17) and pilot (631.00.11). Measure spring (631.00.16) position and then unscrew spring pusher (631.00.14) and remove spring (631.00.16). Remove mid cover (631.00.18) by unscrewing the 10 screws (INS.87.27 or INS.87.30), the 2 screws (INS.87.24 or INS.87.25) and the 10 nuts (INS.89.71).

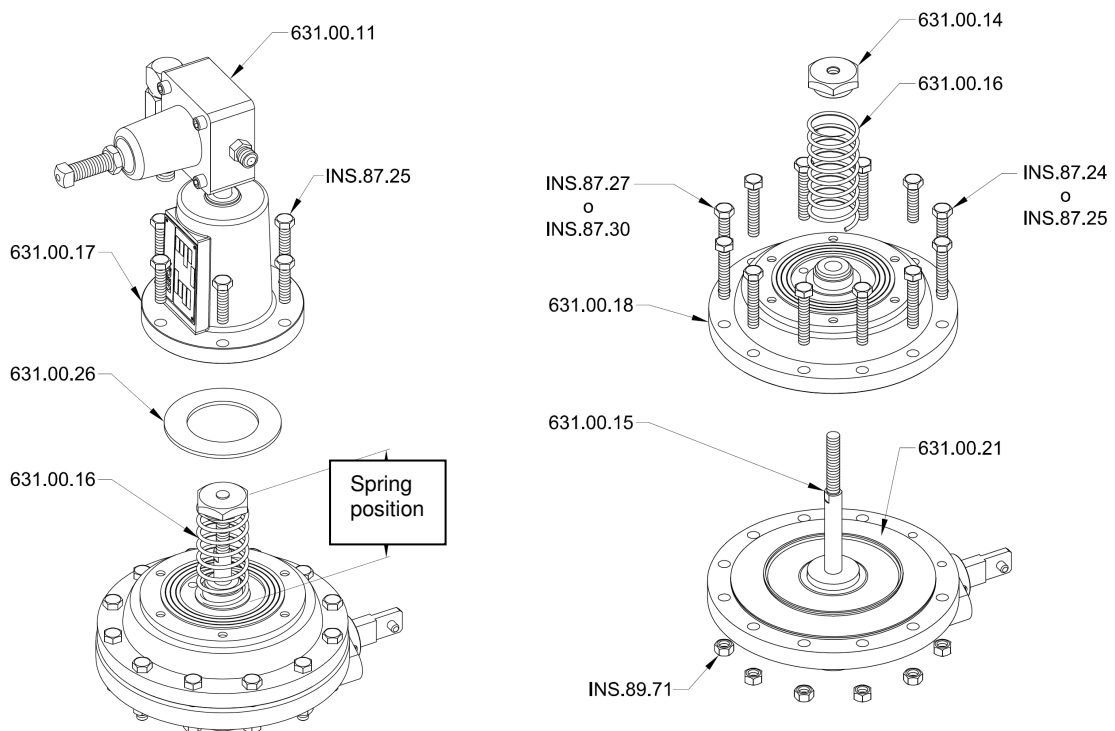

The diaphragm can be replaced with the rest of the spare parts (KIT), or disarm and change it only (631.00.21).

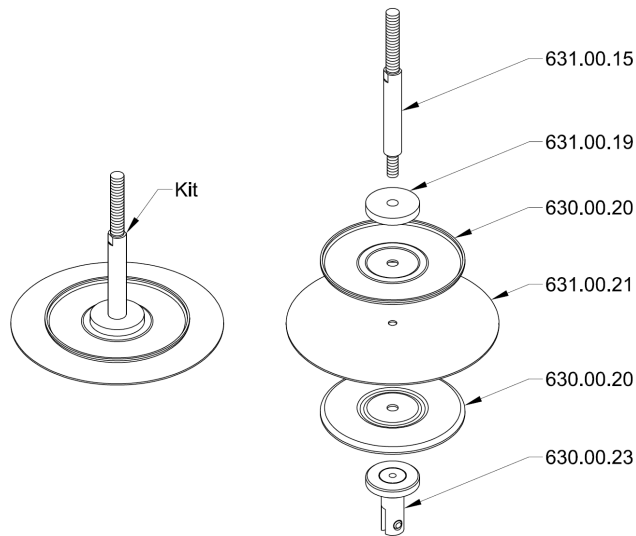

Assemble the diaphragm in the reverse order. Make sure that lever (630.00.06) fits into the diaphragm holder (630.00.23).

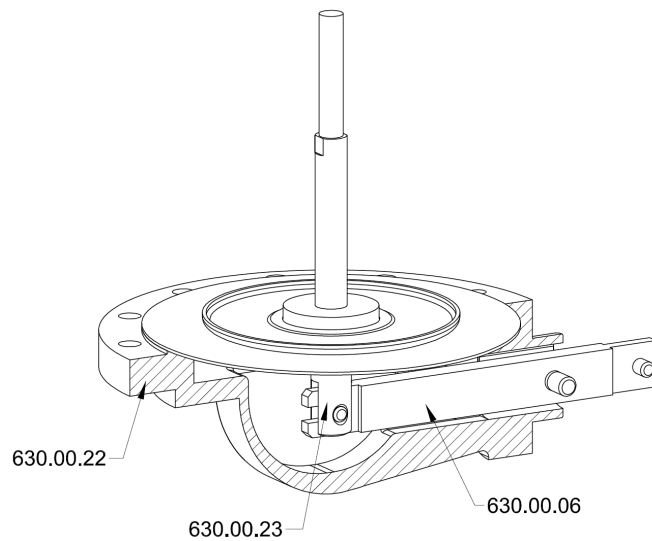

10- Assemble the unit following the instructions in the reverse order and adjust the spring according to pressure gauge indication.

NOTE: If there is no possibility of placing a pressure gauge before removing the regulation screw, measure the distance between the edge of the screw and the pilot (631.00.11) and reassemble respecting that measure.

CAUTION: When tightening the screws (INS.87.39 or INS.86.99), make alternately and control depth so that all are equal. Doing it with caliper and check that the difference does not exceed 0,1 mm. Wrong adjustment may cause a bad shutter closing because of a lack of parallelism.

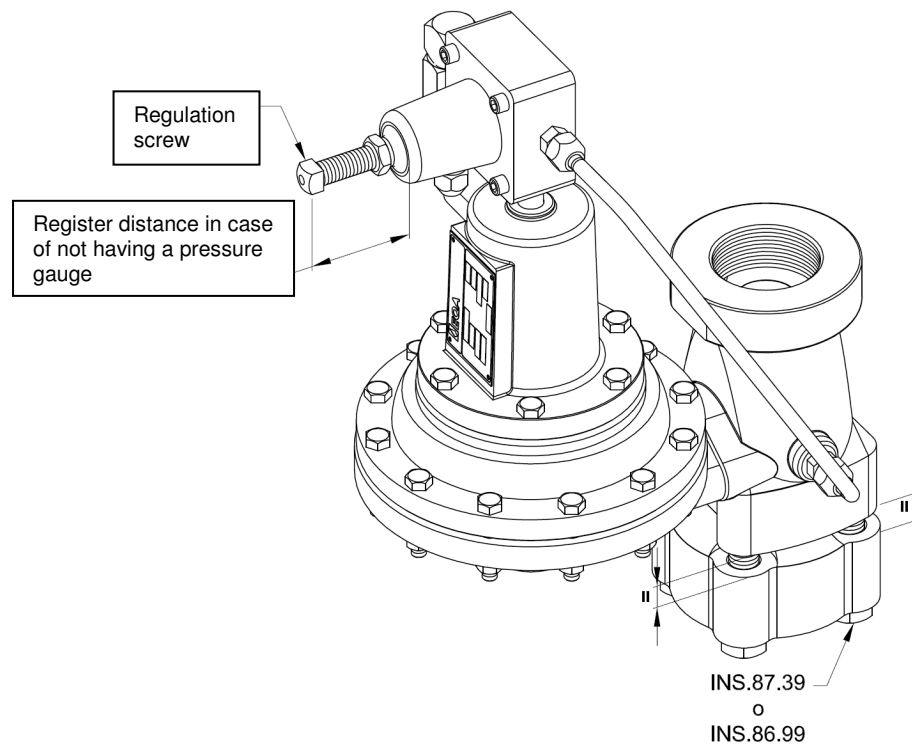

ASSEMBLY

Part list:

625.00.CH - Identification plate.	631.00.14 - Spring pusher.
630.00.02 - Orifice.	631.00.15 - Diaphragm stem.
630.00.03SUB - Shutter. *	631.00.16 - Spring.
630.00.04 - Lever stem.	631.00.17 - Diaphragm cover.
630.00.05 - Shutter stem.	631.00.18 - Mid cover.
630.00.06 - Lever.	631.00.19 - Diaphragm pusher.
630.00.07 - Outlet body.	631.00.21 - Diaphragm. *
630.00.20 - Diaphragm plate.	631.00.26 - Diaphragm cover gasket.
630.00.22 - Diaphragm housing.	631.00.29 - Elbow 1/4"BSP M-F.
630.00.23 - Diaphragm holder.	631.01.30 - Nipple (long) 1/4" BSPT.
630.00.24 - Orifice gasket. *	631.02.30 - Nipple 1/4"BSP – (calibrated orifice).
630.00.25 - Gasket. *	631.00.31 - Conical nut.
631.00.01 - Inlet body.	INS.87.24 - Screw 5/16"W x 1"- Hex. head.
631.00.08 - Inlet pipe.	INS.87.25 - Screw 5/16"W x 1-1/4"- Hex. head.
631.01.09 - Filter.	INS.87.27 - Screw 5/16"W x 1-3/4" - Hex. head.
631.02.09 - Filter body (Stainless steel).	INS.87.30 - Screw 5/16"W x 1-1/2" - Hex. head.
631.03.09 - Filter cover (Stainless steel).	INS.87.39 - Screw 5/8"W x 2-3/4"- Hex. head.
631.04.09 - Filter body (Bronze).	INS.89.71 - Nut 5/16"W.
631.05.09 - Filter cover (Bronze).	INS.86.88 - Screw 3/8"W x 1-1/4" - Allen head.
631.06.09 - Washer.	INS.62.96 - Nipple 1/4" x 50mm - SCH40.
631.00.11 - Pilot.	INS.86.99 - Screw 5/8"W x 2-1/4"W - Hex. head.
631.00.12 - Nipple 1/4"BSP (calibrated orifice)	INS.11.688 - Screw 5/32"W x 1" – Round head.
631.00.13 - Outlet pipe.	OR2.01.7N70 - O'ring.

*Products included in the spare part kit

